



# SURFACES

PANEL SURFACES 001  
SUR-PNL-001

**CSI**  
Creative

PRODUCT GUIDE

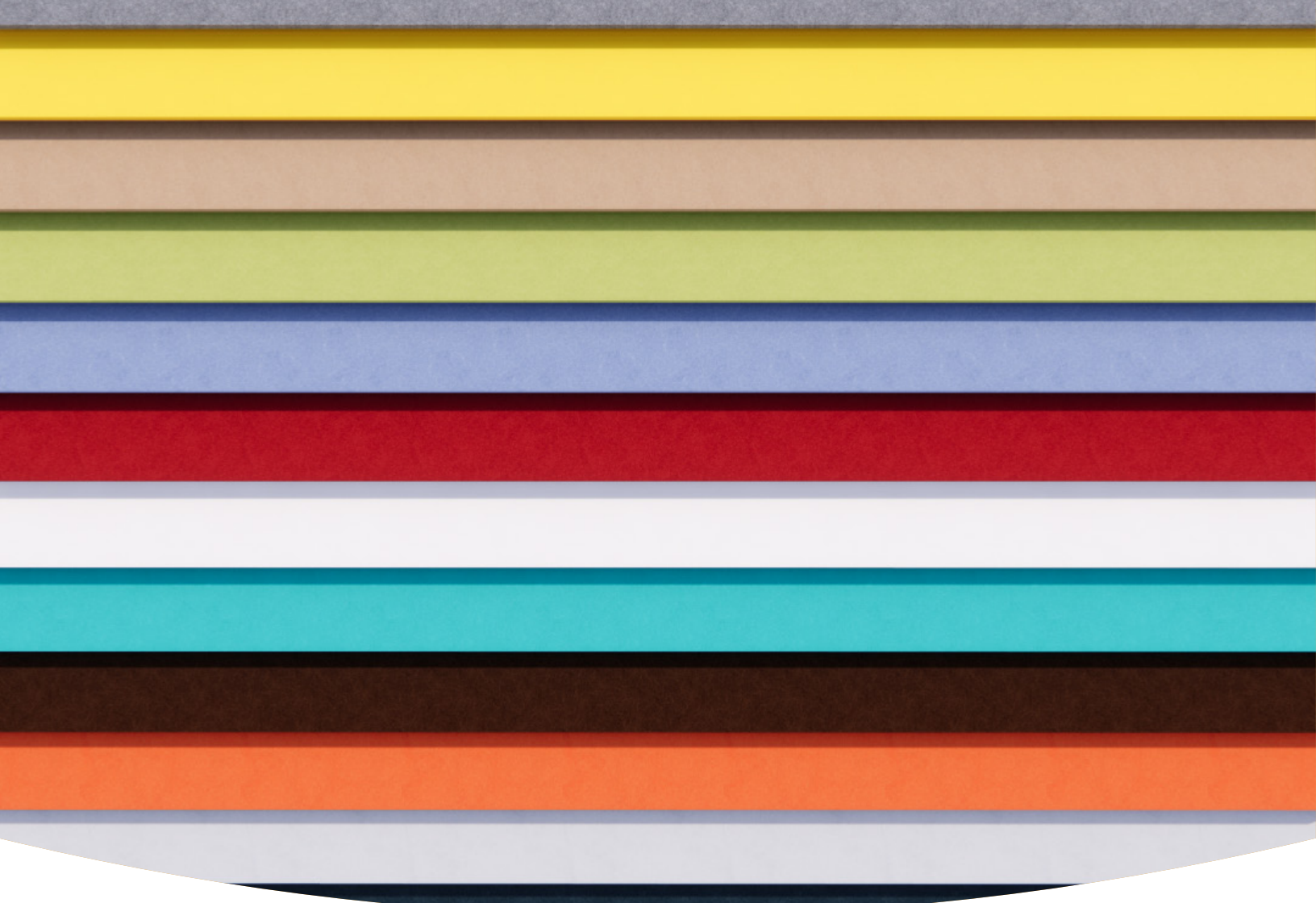

**LIGHTWEIGHT**

Super light material opens up options for ceilings and surfaces.



**POWERFUL ACOUSTICS**

High Noise Reduction Coefficient.



**FIRE-SAFE**

ASTM E84: Class A tested and compliant.



**VOC FREE**

CDPH Standard Method V1.2 School Classroom and Private Office Compliant.



**CUSTOM SIZING**

Custom-sized products arrive installation ready.



**SUSTAINABILITY**

Made from 60% recycled content and is 100% recyclable.



**LOW MAINTENANCE**

A light dusting is all you'll ever need.



**LEAD TIME**

2-4 weeks with vast color options.



# SPECIFICATIONS

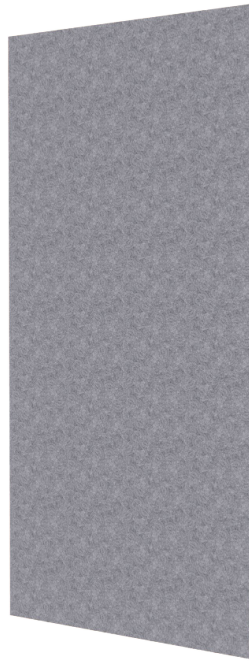

<b>PRODUCT ID</b>	SUR-PNL-001
<b>CONTENT</b>	Soundcore® Recycled PET acoustic felt
<b>DURABILITY</b>	Impact resistant, shock absorbant
<b>WEATHERING</b>	Non-deteriorating, non-hygroscopic, colorfast
<b>MAINTENANCE</b>	Clean with vacuum or light dusting
<b>WARRANTY</b>	Comes with industry-leading standard warranty
<b>ENVIRONMENTAL</b>	LEEDv4, VOC free, 100% recyclable, non-toxic, non-allergenic, anti-microbial
<b>INSTALLATION</b>	CSI Installation Systems are product specific (see Installation page)
<b>ACOUSTICS</b>	0.45 NRC
<b>FLAMMABILITY</b>	ASTM E84: Class A

# TECHNICAL

## LENGTH

48"  
Uncut factory edge

## WIDTH

$\frac{1}{2}$ "  
Uncut factory edge

## HEIGHT

108"  
Uncut factory edge

## MATERIAL THICKNESS

$\frac{1}{2}$ "

## SPACING

varies

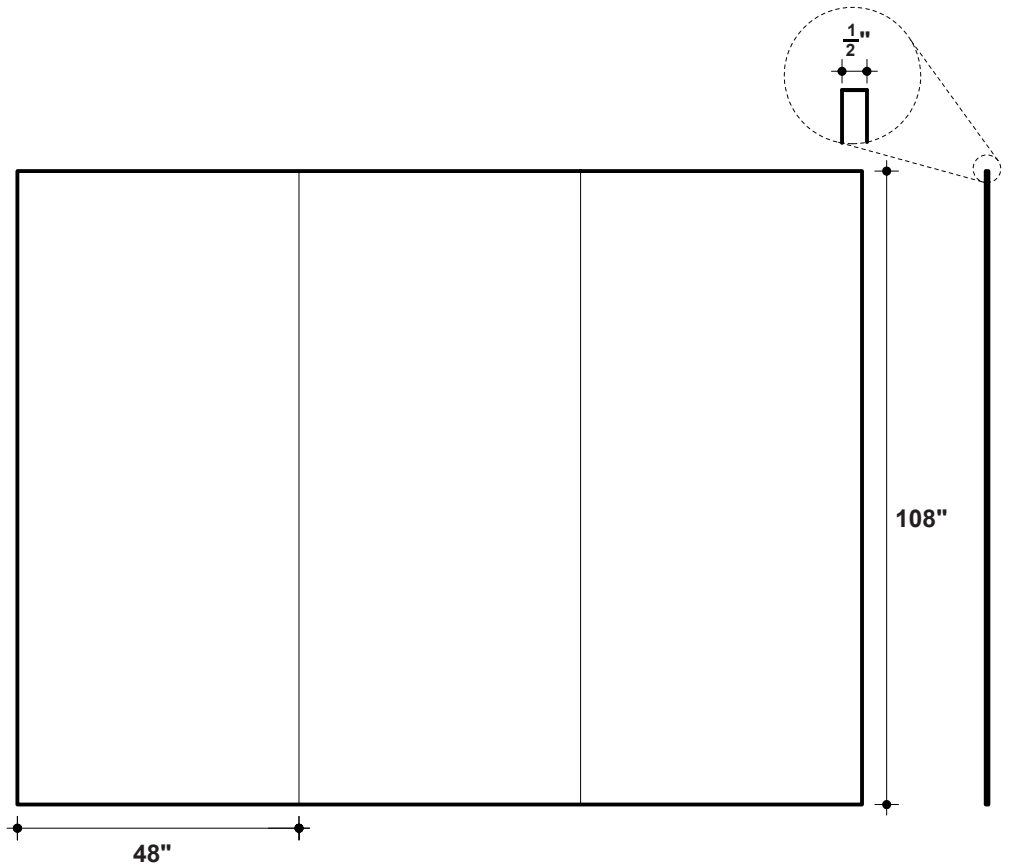

① FRONT & SIDE VIEW

② TOP VIEW

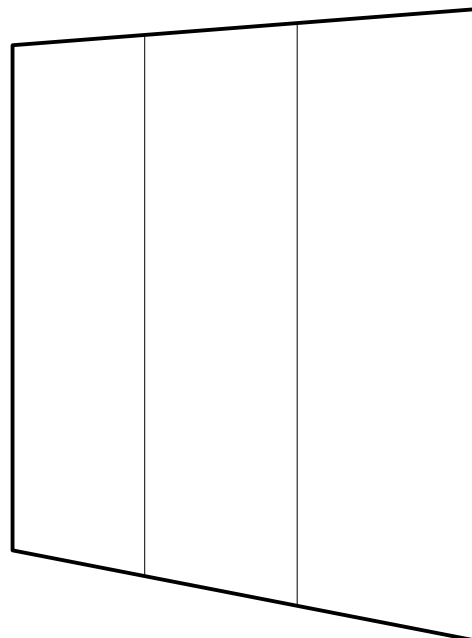

③ PERSPECTIVE VIEW



# INSTALLATION

Surface installation systems are designed according to site conditions, and maximize efficiency of installation.

Each solution respects the integrity of the project design, budget, and installs easily with simple tools.

## DIRECT ATTACHMENT SYSTEM

Attachment solution for pre-constructed ceiling substrates using construction adhesives. Requires minimal skilled installation labor. Ideal for remodeling spaces.

## PEEL AND STICK SYSTEM

Attachment solution for existing surfaces or substrates using pre-applied adhesive backing. Requires minimal skilled installation labor - simply peel, and stick.

## INDIVIDUAL CLIP SYSTEM

Attachment system for hanging multiple panels in series efficiently. Maintains alignment of panels with a drop-in gravity clip system. Easily installed in post-construction phase.

## SNAP MOUNT SYSTEM

Attachment system for efficient installation via pre-designed modular configurations using snap-locking hardware. Engage us in the design phase for site-specific templates and hardware configurations.

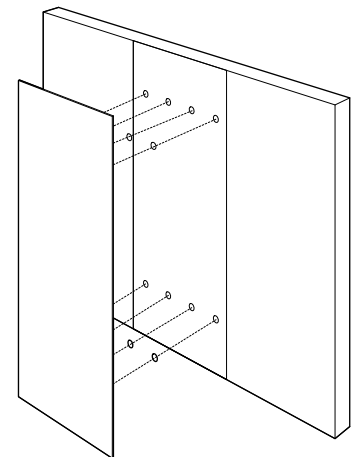
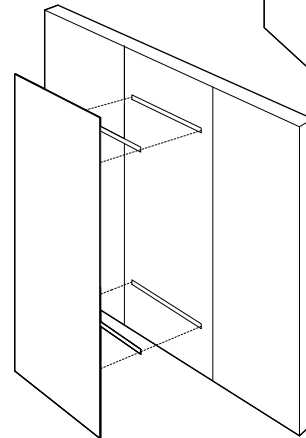
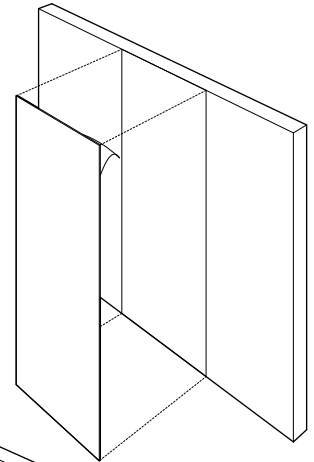
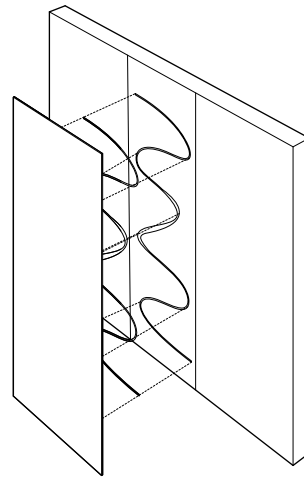

# SITE CONDITIONS

## TRANSITION

Surface installations in transition areas are typically simple, low-profile cladding that uses color to assist in wayfinding, and enhances the acoustics of hard surfaces in hallways.

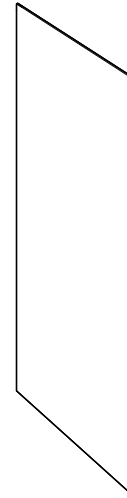

## FOCAL POINT

Surface cladding used as a focal point can be infinitely more complex, and can integrate other materials. A focal point gets much more visual attention than transition spaces, and serves artistic merit as well as acoustics.

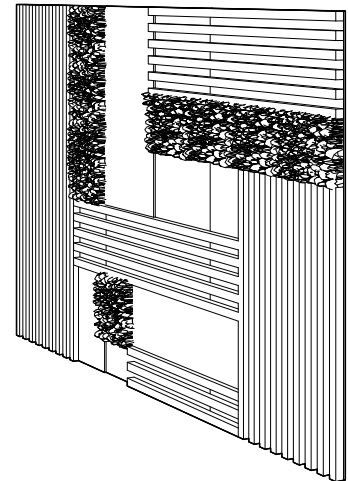

## BRANDING

Any product can be designed with integrated branding opportunities, from color choices to lettering, carving, graphic displays and more.

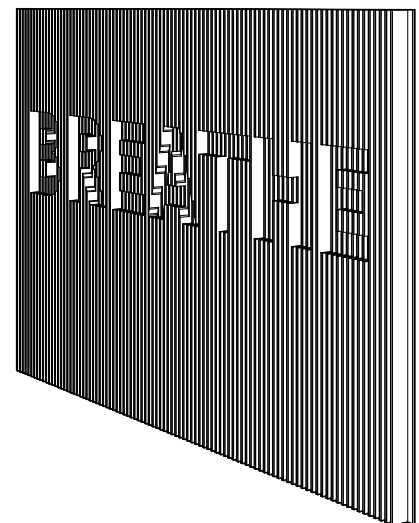



# COLORWAYS

SOUNDCORE® RECYCLED PET ACOUSTIC FELT

## PREMIER COLORS | 1/2", 4' X 9'

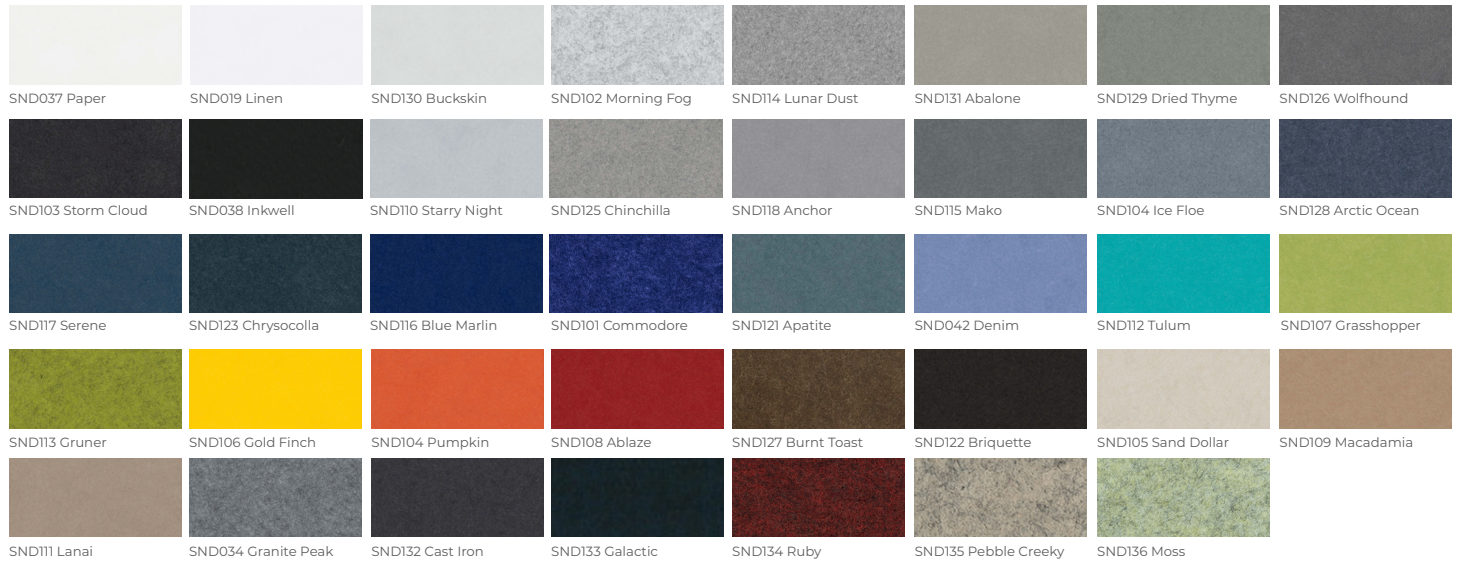

## SECONDARY COLORS | 3/8" X 4' X 8' | Call for lead time



# SOUNDCORE® WOOD TEXTURES RECYCLED PET ACOUSTIC FELT

## PREMIER COLORS | 1/2" X 4' X 9'





# SUSTAINABILITY



## RESPONSIBLE INNOVATION

We source our materials responsibly, using 100% recyclable materials. The majority of the material composition comes from post-consumer plastics, which means you're not forwarding the environmental bill to the next generation.

Soundcore® is 100% VOC free (Volatile Organic Compound), which means from day one there will be zero odorous fumes, and zero air toxicity. It's also ASTM E84: Class A fire rated and offers resonant insulation to build a more comfortable environment.

All of these check-boxes make up a surprisingly lightweight, soft-touch panel that we're incredibly proud of.

## MATERIAL CONSTRUCTION

60% Recycled PET acoustic fiber.

## PRODUCT CERTIFICATIONS

ASTM E84: Class A, VOC Free (CDPH Standard Method V1.2)





# OUR MISSION

---

## EXPERIENTIAL SPACES

Our goal is to create spaces that feel better.

It's easy to visualize a space with architectural acoustics, but even the most detailed renderings couldn't convey the experience of actually being there. When sound is properly controlled within a space, it creates focus and calmness that you can actually feel. We want to help you turn off the droning machinery in the back of your mind. We fabricate custom solutions that visually suit your space while building towards a more soothing holistic experience. This creates spaces where people want to be—where they want to work, where they want to sleep, exercise, create, study, and relax.

